

Installation Instructions for 1530 RESIDENTIAL DUTY BI-FOLD HARDWARE

For 2 or 4 Doors Up to 20 Lbs. each and 7/8" to 1-3/8" Thick

Step 1 PREPARE FINISH OPENING

FINISH OPENING
Height = Door Height + 2"

2 Door Width = 2 X Door Width + 1/2"

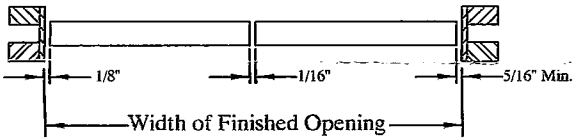

4 Door Width = 4 X Door Width + 7/8"

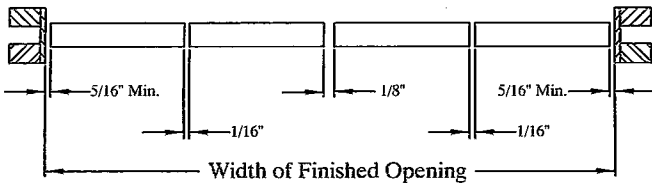

Step 2 APPLY HINGES

To install Hinges place doors side by side.
Hang hinges between doors as spacers to
maintain correct gap.

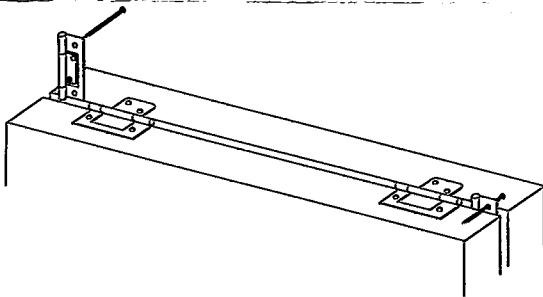

Step 3 DRILL DOORS AND MOUNT PIVOTS & GUIDES

Drill 3/8" holes in top and bottom of the pivot door and
top only of guide door as shown in sketch below.
Install top pivot guide in top of both doors.
Install bottom pivot in bottom of pivoted door only.
Note: Tap pivots and guides into doors gently.

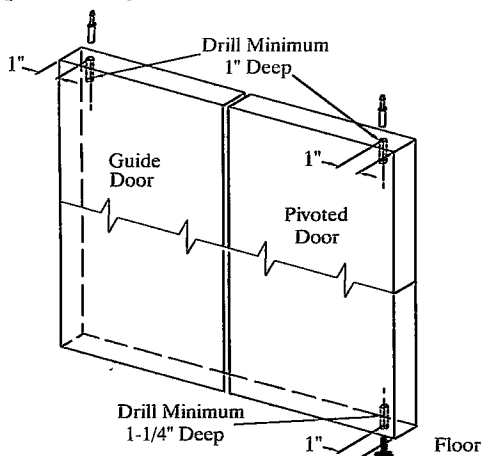

Step 4 MOUNT GUIDE TRACK

Install top pivot bracket in track with screw head on track rails
with bracket end approximately 1" from track end. Mount guide
track to head jamb head using 1" long #6 flat head screws.
For 2-door installation, locate pivot end of track snugly against jamb.

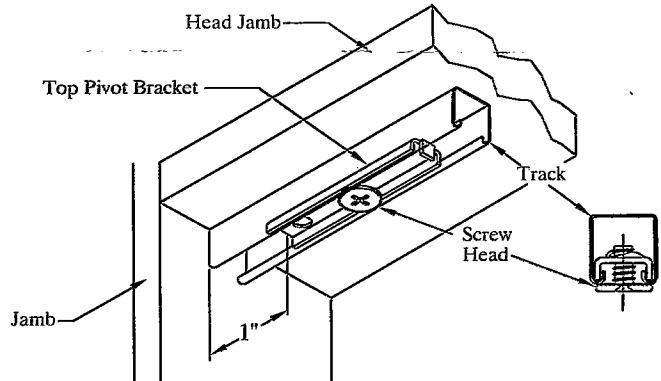

Step 5 INSTALL JAMB BRACKET

Surface mount jamb bracket on finished door jambs at floor level in a
vertical plumb with the guide track screws, using 1" long #6 flat
head screws. Because jamb bracket is made of extra heavy material,
it is acceptable to mount the bracket off the floor. This should only
be done when there is more than the recommended door + 2"
finished opening height.

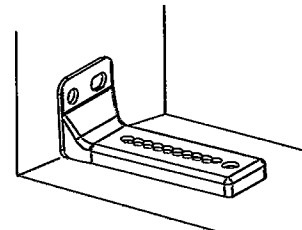

Step 6 INSTALLATION OF DOORS

Fold door panels together and engage top pivot guide into top
pivot socket and top pivot guide into track. Then set bottom
pivot assembly into serations in jamb bracket.

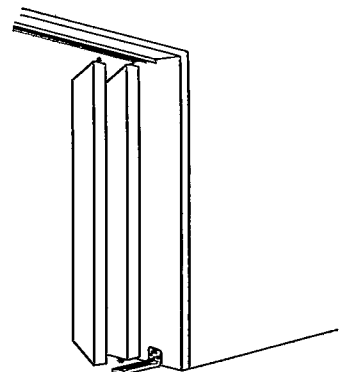

Step 7 VERTICAL AND HORIZONTAL ADJUSTMENT

Horizontal adjustment- Move top pivot bracket in or out to obtain proper clearance between door and jamb. To hold in position tighten screw in bracket. To adjust bottom of door simply lift and set down in different position.

Vertical adjustment- Rotate adjusting bolt on bottom pivot: right to lower door and left to raise it.

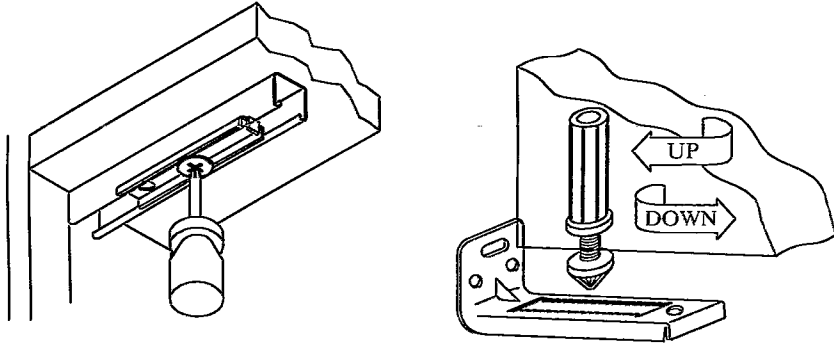

Step 8 INSTALL KNOBS

Drill 3/16" diameter holes approximately 36" from the floor and in the center of the guide door. Fasten with screws provided.

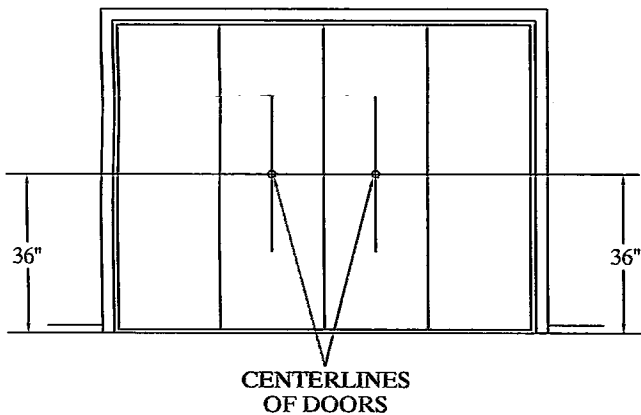

Step 9 LOCATE ALIGNERS

On 4 panel sets, mount aligners on the back side of door panels approximately 12" from the bottom. Use the aligners as templates and drill 3/32" diameter holes and mount using two 3/4" #8 Pan Head screws. Adjust in and out until doors "snap" closed. Tighten screws securely.

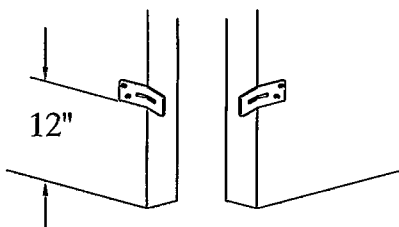

Step 10 SNUGGER

Press self-centering 4 door snagger into the track between the pairs of door panels. In 2 door installations, press the 2 door snagger into the track between the top guide and the jamb farthermost from the pivot.

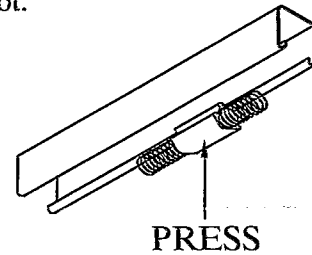

BI-FOLD HARDWARE

Finished Installation

-one pair of folding doors

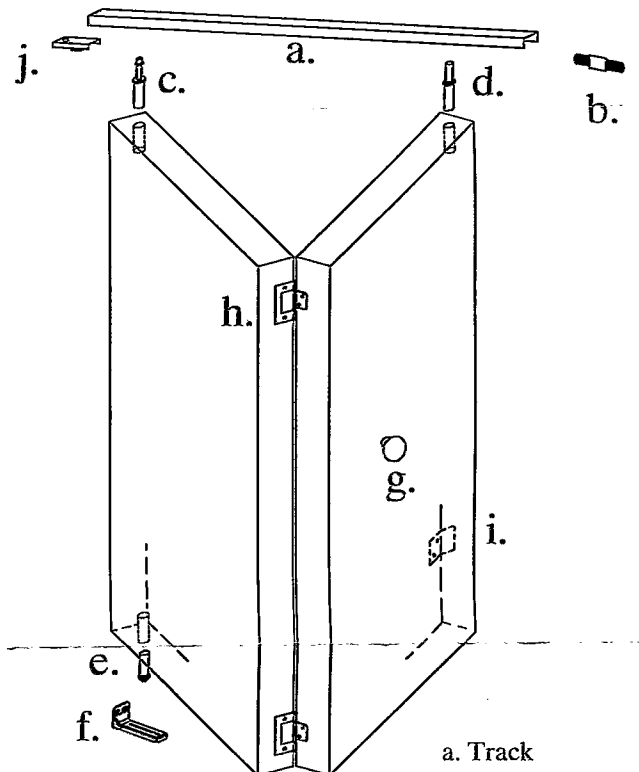

- a. Track
- b. Snagger
- c. Top Pivot
- d. Top guide
- e. Bottom Pivot
- f. Jamb bracket
- g. Wood Knob
- h. Hinges
- i. Aligners
- j. Track Pivot

Butt tracks together
in center of doorway

2" or
less

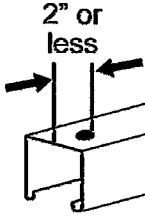

For doorways less than 72", use hacksaw or sheet metal snips to cut each track equally. For best appearance, we recommend installing cut ends of tracks against jambs. In that case, drill a new 3/16" screw hole in each track no more than 2" from end nearest to jamb. (Tip: For easier hole drilling, mark hole location in track by indenting with hammer and nail.)

© Copyright

John Sterling Corporation

Richmond, IL 60071

8008-TC72

Install Top Pivot Brackets approximately 1" from track end nearest to jamb.

Butt tracks together
in center of doorway

2" or
less

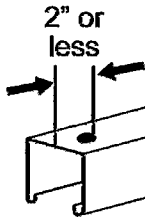

For doorways less than 96", use hacksaw or sheet metal snips to cut each track equally. For best appearance, we recommend installing cut ends of tracks against jambs. In that case, drill a new 3/16" screw hole in each track no more than 2" from end nearest to jamb. (Tip: For easier hole drilling, mark hole location in track by indenting with hammer and nail.)

© Copyright

John Sterling Corporation

Richmond, IL 60071

8008-TC96

Install Top Pivot Brackets approximately 1" from track end nearest to jamb.